

Schalenkern SK 36 x 22
Pot core SK 36 x 22

Magn. Formkenngrößen/Satz
eff. magn. parameters/set

Formfaktor <i>core factor</i>	$C_1 =$	0,26 mm ⁻¹
Eff. magn. Weglänge <i>eff. magn. path length</i>	$l_e =$	52,7 mm
Eff. magn. Querschnitt <i>eff. magn. cross section</i>	$A_e =$	205 mm ²
Eff. magn. Volumen <i>eff. magn. volume</i>	$V_e =$	10800 mm ³
Gewicht <i>weight</i>	$G \approx$	60 g

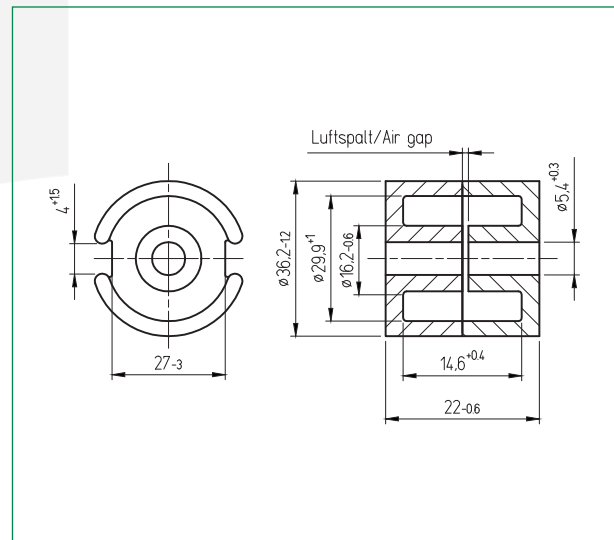

Werkstoff <i>material</i>	A_L -Wert A_L value nH	Toleranz <i>tolerance</i>	Luftspalt <i>airgap</i> mm	μ_e	Bestellnummer <i>order number</i>
K 2005	7500	± 25%	-	≈ 1550	326 360000 025
K 2006	7400	± 25%	-	≈ 1530	326 360000 026
K 4000	12200	± 25%	-	≈ 2520	326 360000 004
K 6000	17000	± 30%	-	≈ 3520	326 360000 006
K 2005	1250	± 5%	≈ 0,16	≈ 260	326 361250 025
K 2005	800	± 3%	≈ 0,28	≈ 165	326 360800 025
K 2005	400	± 3%	≈ 0,65	≈ 85	326 360400 025

All information given without liability. If you require further information about our products, do not hesitate to contact our representatives, or visit our homepage, www.kaschke.de.

Kaschke Components GmbH

Rudolf-Winkel-Straße 6 · 37079 Göttingen · Germany
 Fon +49 (0) 551-5058-6 · Fax +49 (0) 551-65756
kaschke.de